

# Whitepaper

Refrigeration system efficiency improvement with DWEEN Cold

PREPARED BY  
**Zilvinas Salialionis**

2025.01.13

**DWEEN** Cold

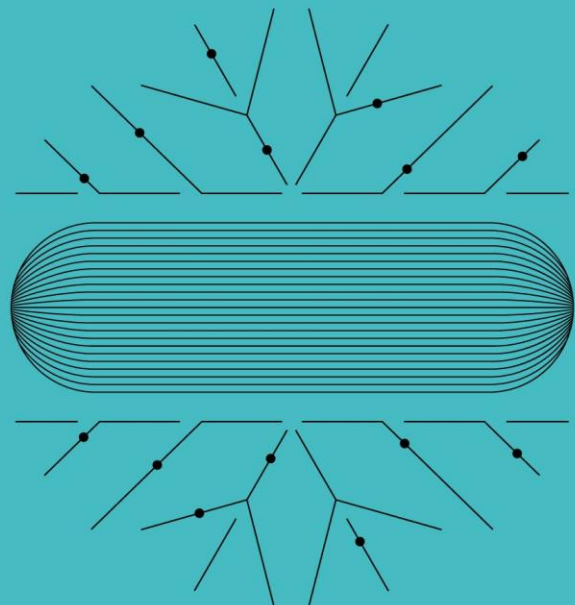

## Executive summary

Dween Cold solution controls refrigeration system ensuring efficient operation of all connected refrigeration units. Reduction of energy consumption is achieved through continuous monitoring of system's performance and advanced control of evaporation temperature and pressure according to the actual refrigeration demand and current production volume.

Several packaged chiller units, different types and cooling capacities can be connected into holistic whole and managed centrally thus assuring optimal operation and reduction of energy consumption.

## Company background

Energy Advice is a Technology Development and Advisory company. Our Cloud based Digital Solutions help energy-intensive industries to increase operational efficiency and sustainability.

Our strength is deep knowledge of engineering systems, technologies and processes. We use real time data analysis in our intelligent products to automate and control process flow, improve quality, reduce energy consumption.

Energy Advice is ISO 27001:2013 and ISO 14001:2015 certified.

## System functionality

- Automated control of a complex refrigeration system based on artificial intelligence at ¼-minute intervals according to the actual refrigeration demand:
  - advanced control of evaporation temperature and pressure,
  - cold production management.
- Real-time assessment of key performance indicators:
  - refrigeration process,
  - compressor station performance,
  - energy consumption.
- Web-based user control panel of Dween Cold system,
- Historical data of refrigeration system performance,
- Daily Food Safety Protocol.

## Operating Services

- Connection of the cooling system to the server (Dween Cloud);
- Digital twin (mathematical model) of refrigeration system in Dween Cloud with mass and energy balance equations,
- Read-out of the status of the entire cooling system (each component) from SCADA (OPC server), PLC, measuring devices at **¼-minute intervals**,
- Real-time estimation of refrigeration demand based on system status and ambient conditions,
- Calculation and adjustment of optimal compressor station settings (evaporation temperature and pressure) according to the actual refrigeration demand and production volume in **¼-minute intervals**,
- Real-time evaluation of key performance indicators, reporting of biased changes:
  - **Energy consumption, refrigeration vs production (kWh/kg)**,
  - Refrigeration process, performance vs energy consumption,
  - Performance of refrigeration system components,
  - Performance of heat exchangers.

## Outcome / Benefits

- Reduction of energy expenses for refrigeration,
- Adoption of refrigeration process to variable production capacity,
- Variable production costs reduction,
- Extended life span of refrigeration equipment,
- 24/7 KPI tracking,
- Data inventory. Compressor station, consumer side equipment and technological process data is collected and stored at Dween Cloud,
- Refrigeration system operation information and historical usage data for production traceability,
- Predefined refrigeration system operation KPI reports,
- Decreased maintenance and repair costs due to data driven decisions,
- Easier training for new operating personnel, increased productivity,
- Reduction of CO<sub>2</sub> emission,
- Sustainability.

# Example of the system diagram

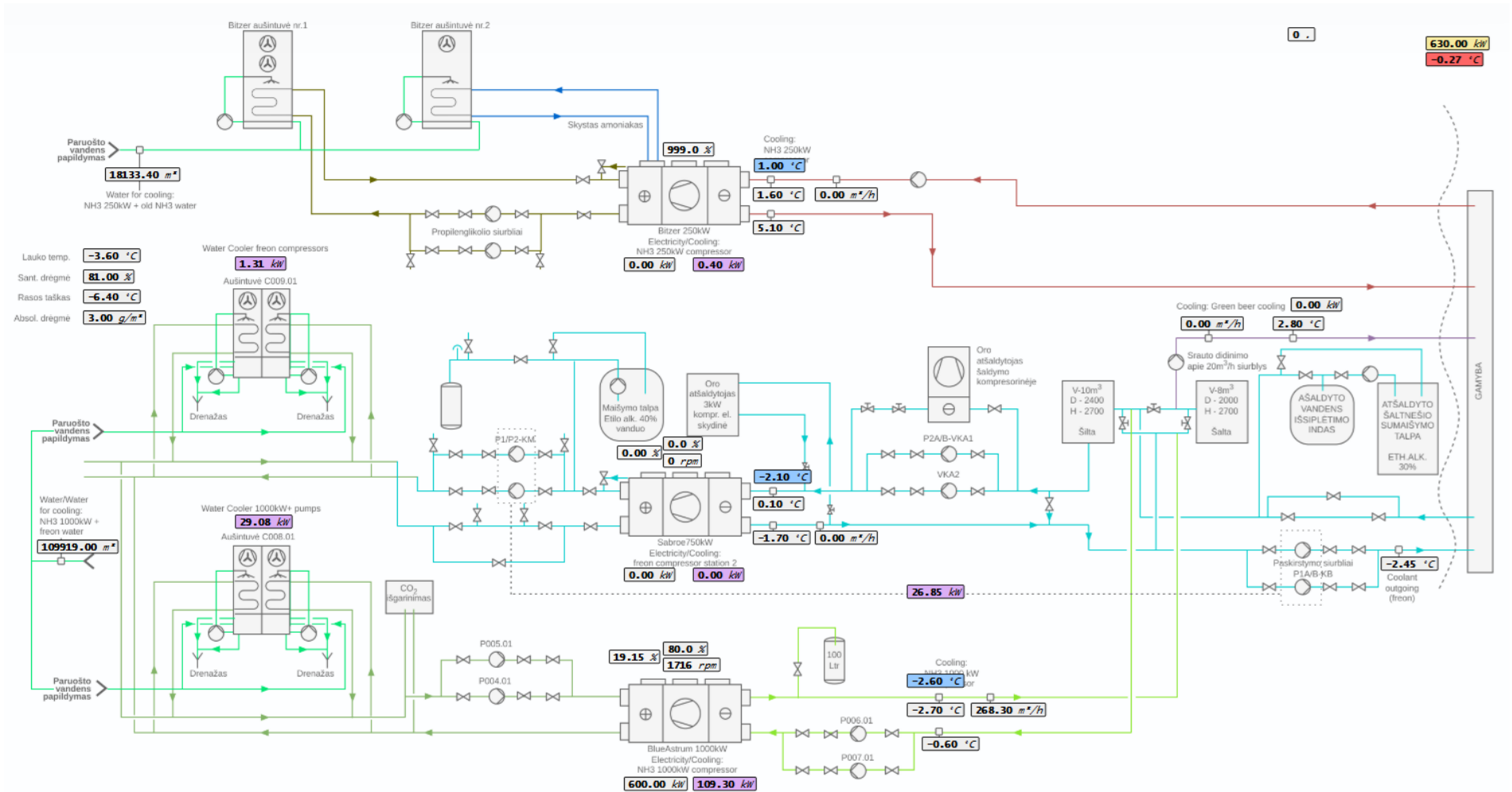

Picture 1 - Example of the system diagram

## Example of energy consumption graph

Automatic control of refrigeration system was activated on 1st of March:

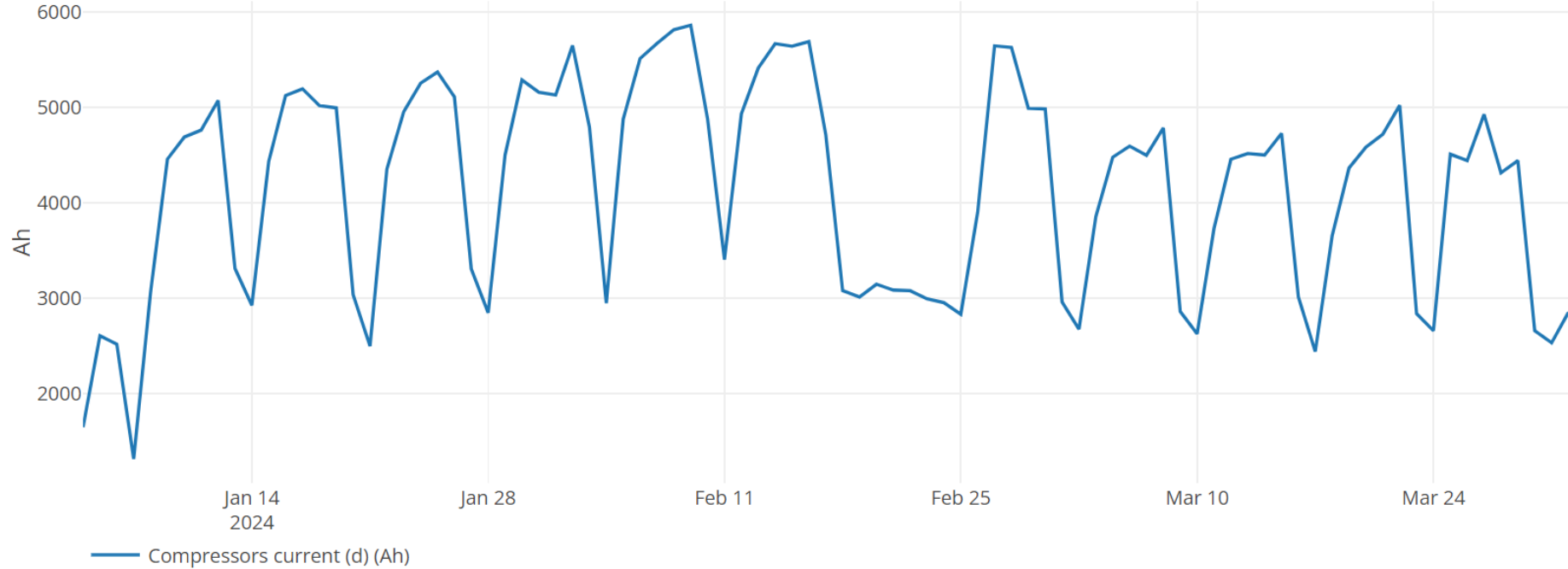

Picture 2 - Example of energy consumption graphs